

Serviceanleitung • Service Manual

(D) Weitere Dokumentationen

Schaltbild	8 622 401 339
Ersatzteilliste	8 622 401 238
Service Anleitung LW SCA 4.4	8 622 400 242

(GB) Supplementary documentation:

Circuit diagram	8 622 401 339
Spare part list	8 622 401 238
Service manual of mechanism SCA 4.4	8 622 400 242

Achtung:

Bei Arbeiten an den unter Spannung stehenden und nicht mit entsprechenden Filtern oder Streuscheiben abgedeckten LED's, müssen Sie folgende Sicherheitsvorschriften beachten:

1. Reparaturen oder Funktionsprüfungen dürfen nur mit einer Schutzbrille erfolgen.
Die zu verwendenden Sichtscheiben müssen einen UV- bzw. Sonnenschutzfilter haben (z.B. UVEX sportstyle 9186 088).
2. Der Betrieb mit höheren Strömen, auch kurzzeitig, ist nicht zulässig.
3. Der Blickwinkel zur Leiterplatte darf 60° nicht übersteigen.

Die Nichtbeachtung der Verarbeitungsvorschriften kann schwere Augenschädigungen zur Folge haben!

Attention:

For the process of handling the LEDs while they are supplied with their operating voltage and not covered by their respective filters or diffuser screens, the following instructions must be observed:

1. Repairs and function checks may be carried out with protection glasses only.
The used glass material must have a UV- or sun ray protection filter (e. g. UVEX sportstyle 9186 088).
2. The operation with higher currents, also for short duration, is not permitted.
3. The viewing angle towards the circuit board may not exceed 60°.

In the case of non-observance of the instructions serious damage to the eyes may result.

Inhaltsverzeichnis

Sicherheitshinweise	1
Auslieferungszustände	2
Belegung des Anschlußkästchens	2
Voreinstellungen / Abgleichhinweise	3
Bedienungshinweise	4 + 5
Demontage	6 - 8
Antennenanpassung	9
Programmierung der Geräteparameter	10,11,14,15
Darstellung der Abgleichelemente	12
Darstellung der Meßpunkte	13
FM-Abgleich	16 - 18
AM-Abgleich (Audi Chorus)	19
AM-Abgleich (Audi Concert)	20 + 21
Dolby-Abgleich	21

Table of Contents

Safety instructions	1
Ex-factory condition	2
Pin assignment of quick-fit connector	2
Pre-adjustments / alignment instructions	3
Operating instructions	4 + 5
Dismantling	6 - 8
Antenna matching	9
Programming of product parameters	10,11,14,15
Representation of alignment elements	12
Representation of measuring points	13
FM alignment	16 - 18
AM alignment (Audi Chorus)	19
AM alignment (Audi Concert)	20 + 21
Dolby alignment	21

D Auslieferungszustände

Audi Chorus

Das Autoradio kann mit 2 passiven Lautsprechern vorn und wahlweise mit 2 aktiven Lautsprechern hinten betrieben werden. Die Umschaltung erfolgt über Diagnosebus.

Auslieferungszustand: Defaultwerte (über Diagnosebus)
Fader aktiv,
LS hinten angeschlossen

Audi Concert

Das Autoradio kann mit zwei passiven Lautsprechern und zwei aktiven Lautsprechern oder als Bose-Soundanlage betrieben werden. Außerdem kann das Gerät in den US-Mode umgeschaltet werden. Die Umschaltung erfolgt über Diagnosebus.

Auslieferungszustand: Defaultwerte (über Diagnosebus)
Standard-Lautsprecher
Europa-Mode

GB Ex-factory condition

Audi Chorus

This car radio can be operated with 2 passive front loudspeakers and of choice with 2 active rear loudspeakers. The switching-over takes place by means of the diagnosis bus.

Ex-factory condition: Default values (via diagnosis bus)
Fader active
Rear loudspeakers connectable

Audi Concert

This car radio can be operated with 2 passive and 2 active loudspeakers or as a Bose sound system. In addition the unit can be switched to the US mode. The switching-over takes place by means of the diagnosis bus.

Ex-factory condition: Default values (via diagnosis bus)
Standard loudspeakers
Europe mode

Belegung des Anschlußkästchens

Pin assignment of quick-fit connector

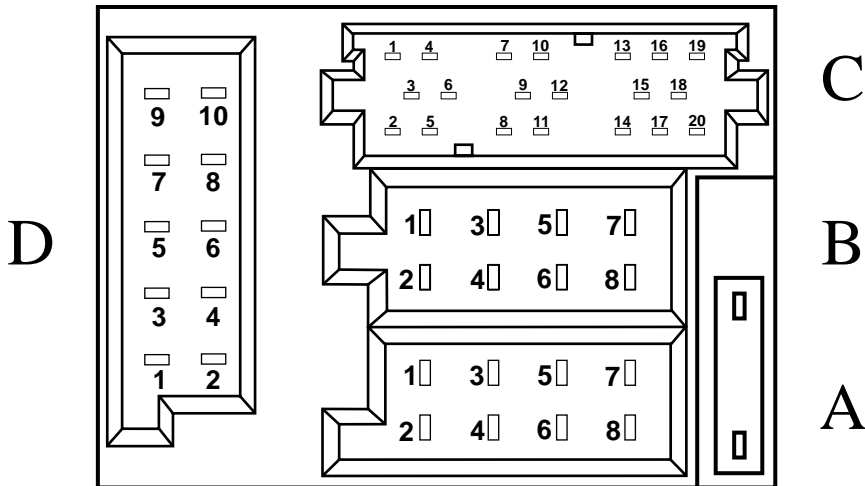

A		B		D	
1	Gala input	1	n.c.	1	Telefon Mute / telephone mute
2	Externer Mute / External muting	2	n.c.	2	n.c.
3	K-Leitung (D.Bus) / K link (D.- bus)	3	NF vorne rechts / AF right front	3	NF/AF +
4	S-Kontakt / S-contact	4	NF Masse / AF ground	4	NF/AF -
5	Automatik Antenne / Automatic antenna	5	NF vorne links / AF left front	5	NF/AF+
6	Beleuchtung 1 / Illumination 1	6	NF Masse / AF ground	6	NF/AF -
7	Dauerplus / Permanent plus	7	n.c.	7	Steuerleitung Nav / Nav pilot line
8	Masse / Ground	8	n.c.	8	Telefon Mute / Telephone mute
9				9	Beleuchtung 2 / Illumination 2
10				10	Masse CDC / CDC ground

C					
1	Line out LR	7	n.c	13	CDC Data in
2	Line out RR	8	Zweitdisplay Clock / 2nd display Clock	14	CDC Data out
3	Line out Masse / Line out ground	9	Zweitdisplay Data / 2nd display Data	15	CDC Clock
4	Line out LF	10	Zweitdisplay Ena / 2nd display Enable	16	CDC Dauerplus / CDC perman. plus
5	Line out RF	11	Fernbedienung / Remote control	17	CDC Steuerleitung / CDC pilot line
6	+12 V (Verstärker) / +12 V (amplifier)	12	n.c	18	CDC NF Masse / CDC AF ground
				19	CDC NF in links / CDC AF Line-in, left
				20	CDC NFin rechts / CDC AF Line-in, right

mechan. Bauteile
Composants mécaniques

mechanical parts
Componentes mecánicas

	(D)	(GB)	(F)	(E)	
ME 3140	DECKEL (OBEN)	HOUSING COVER	COUVERCLE DE BOIT.	TAPA DEL CARTER	8 635 131 600
ME 3142	DECKEL (UNTEN)	HOUSING COVER	COUVERCLE DE BOIT.	TAPA DEL CARTER	8 635 131 601
ME 3180	RÜCKWAND (KAPPE)	REAR PANEL (CAP)	PANNEAU ARRIERE (CAPUCHON)	PANEL TRASERO (CASQUETE)	8 630 060 175
ME 3220	DREHFEDER (CR-KLAPPE)	TORSION SPRING (CC-FLAP)	RESSORT DE TORSION (TRAPPE CC)	RESORTE DE TORSIÓN (TAPADERA CC)	8 634 650 175
ME 3470	LICHTLEITER	LIGHT CONDUCTOR	PL. POUR LAMPES	CONEXION FIBRA OPTICA	8 635 370 438
X 1001	STIFTLEISTE (14 POL.)	PIN CONNECTOR	BARRETTE A TIGES	REGLETA DE CLAVIJA	8 638 801 193
X 1301	BUCHSENLEISTE (8 POL.)	FEMALE CONNECTOR	REGLETTE DE BORNES	REGLETA DE BORNES	8 638 800 541
X 1302	STECKERGEÄUSE (5 POL.)	PLUG HOUSING	BOITIER DE FICHE	CAJA DE CLAVIJA	8 908 603 421
X 1000	BUCHSENLEISTE (14 POL.)	FEMALE CONNECTOR	REGLETTE DE BORNES	REGLETA DE BORNES	8 638 801 192

ME 3401
Audi chorus
8 636 590 303
Audi concert
8 636 590 309









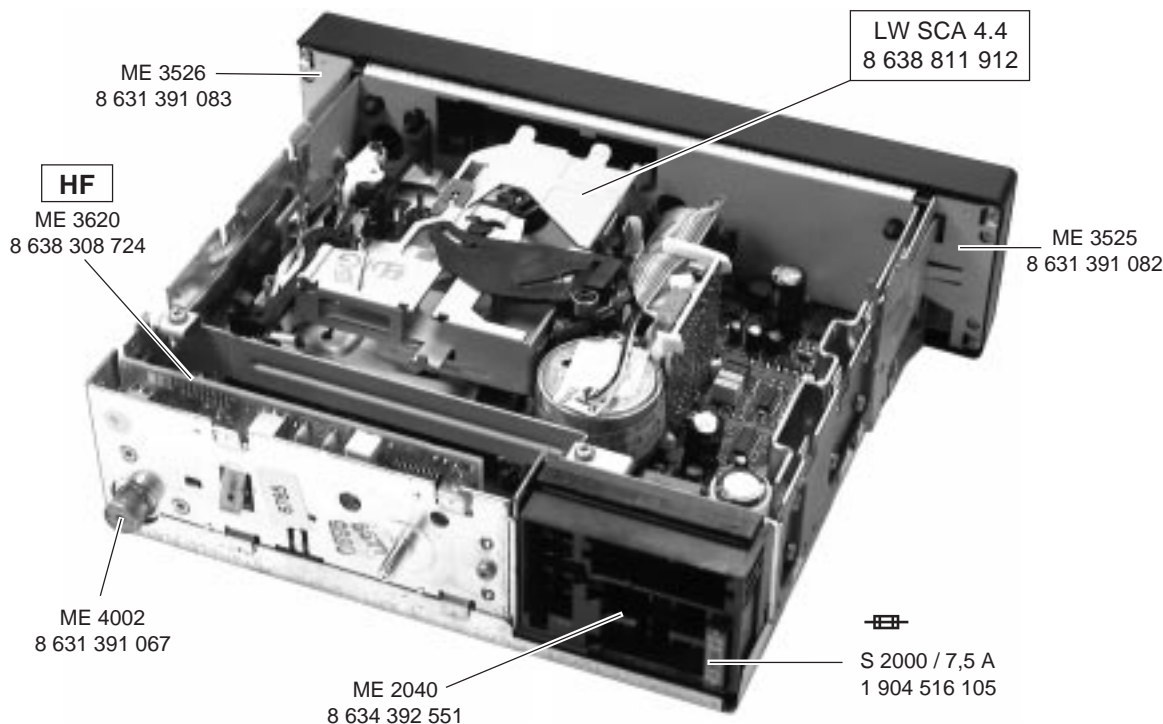
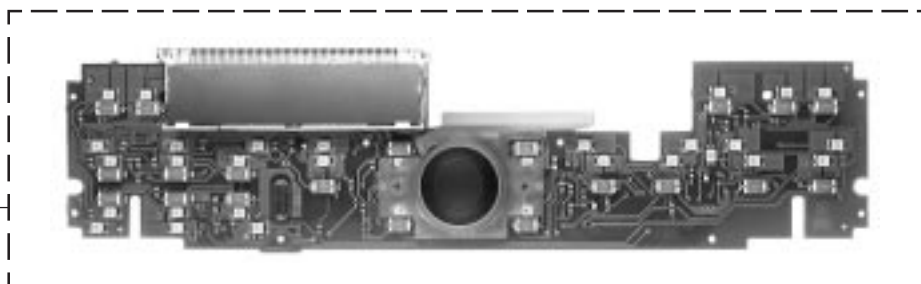

(Die abgebildete Einheit ist nur komplett zu wechseln, da die Kontaktierung der Folie nur im Fertigungsprozess möglich ist.)
(The illustrated unit must be exchanged completely, as the contact assignment of the foil can only be done in the manufacturing process.)
(N'échanger l'unité illustrée que complètement, car le bonding de la feuille est seulement possible pendant le processus de fabrication.)
(Hay que recambiar la unidad ilustrada completamente, ya que la asignación de los contactos sólo es posible dentro del proceso de fabricación.)

LCD + Schalterplatte







LCD + Switch board,
LCD + Plaque d'interruption,
LCD + Placa de interrupt







ME 3650
Audi chorus
8 638 812 082
Audi concert
8 638 812 081



Position Position Position Posición	Bezeichnung Designation Dénomination Denominación	Bestell-Nr. Part no. No. de commande Número de pedido
HAUPTPLATTE, MAIN BOARD, PLAQUETTE PRINCIPALE, PLACA PRINCIPAL		
		
C 2000	3300 µF	8 943 490 359
	 	
D 310	TDA 1592	8 925 901 456
D 660	TDA 1072 A	8 925 900 247
D 800	MC 68HC05B32	8 925 904 134
D 810	M 74HC132	8 925 901 841
D 820	MC 14551	8 925 900 912
D 830	MC 68HC05C8	8 925 904 143
D 1100	HA 1299 F	8 925 901 837
D 1100	HA 12194 F	8 925 901 838
D 1400	TDA 7342	8 925 901 723
D 1500	MC 14551	8 925 900 912
D 1501	LM 837	8 925 900 205
D 1502	LM 837	8 925 900 205
D 1573	LM 837	8 925 900 205
D 1600	TDA 7376 B	8 945 903 286
D 2010	BSP 452	8 925 705 301
D 2011	BSP 452	8 925 705 301
D 2012	BSP 452	8 925 705 301
D 2051	MC 78M05	8 945 902 581
D 2050	MC 78L05	8 925 901 517
D 2060	L 4949	8 925 901 447
D 2061	L 4952	8 925 901 732
D 2200	MSM 6688	8 925 901 429
D 2201	MSM 6684	8 925 901 527
D 2400	TMS 375C006	8 925 901 774
D 2450	TDA 7332	8 925 900 477
D 8210	LM 258D	8 925 900 905
D 8250	RC 4558	8 925 900 308
		
H 1020	LHT 774	8 925 405 212
		
L 600		8 948 411 059
L 602		8 948 415 077
L 603		8 948 415 056
L 604		8 948 411 059
L 650		8 948 415 055
L 660		8 948 413 008
L 800		8 948 411 060
L 830		8 948 411 060
L 2000		8 948 411 090
L 2000		8 948 411 065
L 2030		8 948 411 089
L 2400		8 948 411 060
L 2450		8 948 411 060
		
R 1210/ R 1220	4,7 kΩ	8 921 500 004
	 	
V 311	DTC 143 ZK	8 925 705 234
V 315	BAL 99	8 925 405 137
V 340	BC 848 B	8 925 705 043
V 341	BAL 99	8 925 405 137
V 342	BC 848 B	8 925 705 043
V 600	Z 47	8 925 421 048

Position Position Position Posición	Bezeichnung Designation Dénomination Denominación	Bestell-Nr. Part no. No. de commande Número de pedido
V 601	BB 512	8 925 405 159
V 602	BB 512	8 925 405 159
V 603	BAL 99	8 925 405 137
V 604	BAL 99	8 925 405 137
V 605	ON 4228	8 925 705 115
V 606	BC 858 C	8 925 705 141
V 607	BC 858 C	8 925 705 141
V 608	BFS 19	8 925 705 282
V 609	BFR 30	8 925 705 131
V 650	BB 512	8 925 405 159
V 690	BC 848 B	8 925 705 043
V 811	BC 848 B	8 925 705 043
V 812	BC 848 B	8 925 705 043
V 820	BC 848 B	8 925 705 043
V 821	BC 848 B	8 925 705 043
V 823	BAV 99	8 925 405 124
V 824	BC 848 B	8 925 705 043
V 825	BAL 99	8 925 405 137
V 840	BC 848 B	8 925 705 043
V 841	BAW 56	8 925 405 015
V 870	BC 858 B	8 925 705 038
V 871	BC 858 B	8 925 705 038
V 872	BAV 70	8 925 405 122
V 1050	BC 848 B	8 925 705 043
V 1055	BC 848 C	8 925 705 139
V 1100	BC 848 B	8 925 705 043
V 1500	BC 848 C	8 925 705 139
V 1501	BC 848 C	8 925 705 139
V 1502	BC 848 C	8 925 705 139
V 1503	BC 858 C	8 925 705 039
V 1504	BC 858 C	8 925 705 039
V 1550	BAL 99	8 925 405 137
V 2000	S 3 G	8 925 405 023
V 2011	BAS 21	8 925 405 182
V 2012	BC 858 C	8 925 705 039
V 2013	BAS 21	8 925 405 182
V 2012	BC 858 C	8 925 705 039
V 2030	FMMT 493	8 925 705 192
V 2031	BC 858 B	8 925 705 038
V 2032	BC 858 B	8 925 705 038
V 2033	BC 848 C	8 925 705 139
V 2034	BC 848 C	8 925 705 139
V 2035	BC 848 B	8 925 705 043
V 2036	BC 848 C	8 925 705 139
V 2061	RLR 4001	8 925 800 044
V 2062	BC 848 C	8 925 705 139
V 2063	BC 848 C	8 925 705 139
V 2064	BAL 99	8 925 405 137
V 2080	BCX 53-16	8 925 705 137
V 2081	BC 858 C	8 925 705 039
V 2082	BC 848 B	8 925 705 043
V 2085	BAL 99	8 925 405 137
V 2200	BC 858 C	8 925 705 039
V 2201	BC 848 C	8 925 705 139
V 2202	DTC 144EKT	8 925 705 264
V 2203	DTC 144EKT	8 925 705 264
V 2300	BC 858 B	8 925 705 038
V 2470	BC 858 C	8 925 705 039
V 2471	BC 858 C	8 925 705 039
V 2472	BC 858 C	8 925 705 039
V 2473	BC 848 C	8 925 705 139
V 2474	BC 848 C	8 925 705 139
V 2475	BAW 56	8 925 405 015
V 2800	BC 858 B	8 925 705 038
V 2801	BAV 99	8 925 405 124
V 5301	BC 848 B	8 925 705 043
V 5302	BZX 84/C5V6	8 905 421 459
V 5303	BZX 84/C5V6	8 905 421 459
V 5304	BZX 84/C5V6	8 905 421 459

Position Position Position Posición	Bezeichnung Designation Dénomination Denominación	Bestell-Nr. Part no. No. de commande Número de pedido
V 8200	BC 808-25	8 925 705 042
V 8202	BC 808-25	8 925 705 042
V 8210	BZX 84/C4V7	8 925 421 061
V 8219	BAL 99	8 925 405 137
V 8220	BC 846 B	8 925 705 229
V 8221	BZX 84/C18	8 925 421 059
V 8222	BC 858 C	8 925 705 039
V 8223	BC 848 C	8 925 705 139
V 8224	BC 858 C	8 925 705 039
V 8225	BC 818-40	8 925 705 228
V 8226	BZX 84/C12	8 925 421 044
V 8227	BZX 84/C12	8 925 421 044
V 8228	BAV 70	8 925 405 122
V 8230	BZX 84/C4V7	8 925 421 061
V 8250	BZX 84/C4V7	8 925 421 061
V 8251	BC 848 B	8 925 705 043
		
Z 310		8 946 193 307
Z 800		8 926 193 002
Z 660		8 946 193 039
Z 850		8 946 193 039
Z 2200		8 926 193 018
Z 2410		8 926 193 001
HF - PLATTE, HF BOARD, PLAQUETTE HF, PLACA HF		8 638 308 724
		
D 3	TDA 1575 T	8 925 900 339
D 152	TDA 1597 T	8 925 901 450
D 180	TL 072 IDR	8 925 900 201
D 700	SDA 4331	8 925 901 532
		
L 1		8 958 411 133
L 2		8 948 419 063
L 3		8 958 411 000
L 4		8 948 419 063
L 6		8 948 419 043
L 9		8 928 411 059
L 50		8 928 411 059
L 601		8 958 411 133
L 700		8 928 411 060
L 701		8 928 411 058
		
R 166	100 kΩ	8 921 500 006
		
V 1	BF 999	8 925 705 280
V 2	BC 858 C	8 925 705 039
V 4	BB 814	8 925 405 146
V 8	BB 814	8 925 405 146
V 15	BB 814	8 925 405 146
V 21	BA 885	8 925 405 530
V 50	S 247 Z	8 925 421 079
V 159	1 N 4148	8 925 405 233
V 181	BAV 99	8 925 405 124
V 183	BC 848 C	8 925 705 037
V 741	BC 848 C	8 925 705 037
		
Z 1		8 948 417 028

Position Position Position Posición	Bezeichnung Designation Dénomination Denominación	Bestell-Nr. Part no. No. de commande Número de pedido
Z 150		8 926 193 201
Z 151		8 926 193 201
Z 152		8 948 417 027
Z 155		8 926 193 201
Z 700		8 926 193 002
SCHALTERPLATTE SWITCH BOARD PLAQUE D' INTERR. PLACA DE INTERR.		
		
D 1000	ST 6280BQ6	8 925 901 775
D 1001	LM 258 D	8 925 900 905
D 1070	MC 14094	8 925 900 913
		
H 1001-		
H 1085	LST 676 P/Q	8 925 405 446
		
L 1000		8 948 420 016
		
S 850-		
S 885		8 638 800 630
		
S 890		8 941 481 057
		
V 1021	SFH 320-3	8 925 705 189
V 1022	BC 858 B	8 925 705 038
V 1028	DTC 143 ZK	8 925 705 234
V 1029	BC 818-25	8 925 705 041
V 1046	DTC 143 ZK	8 925 705 234
V 1048	BC 818-25	8 925 705 041
V 1086-		
V 1091	DTC 143 ZK	8 925 705 234
V 1092	DTA 143 ZKA	8 925 705 233
V 1093	DTC 143 ZK	8 925 705 234
V 1094	DTA 143 ZKA	8 925 705 233
V 1095	BC 808-25	8 925 705 042
V 1096	DTC 143 ZK	8 925 705 234
		
Z 1009		8 926 193 012
Hinweis: Handelsübliche Kondensatoren und Widerstände sind in der Ersatzteilliste nicht aufgeführt. Wir bitten Sie, diese Teile im Fachhandel zu beziehen.		
Note: Capacitors and resistors usual in trade are not mentioned in the spare parts list. Kindly buy these parts from the specialized trade.		
Nota: Des condensateurs et résistances commerciaux ne sont pas inclus dans la liste des pièces détachées. Veuillez acheter ces pièces chez votre spécialiste.		
Nota: No se indican en la lista de piezas de repuestos los condensadores y los resistores de uso comercial. Les rogamos comprar esas piezas en el comercio especializado.		

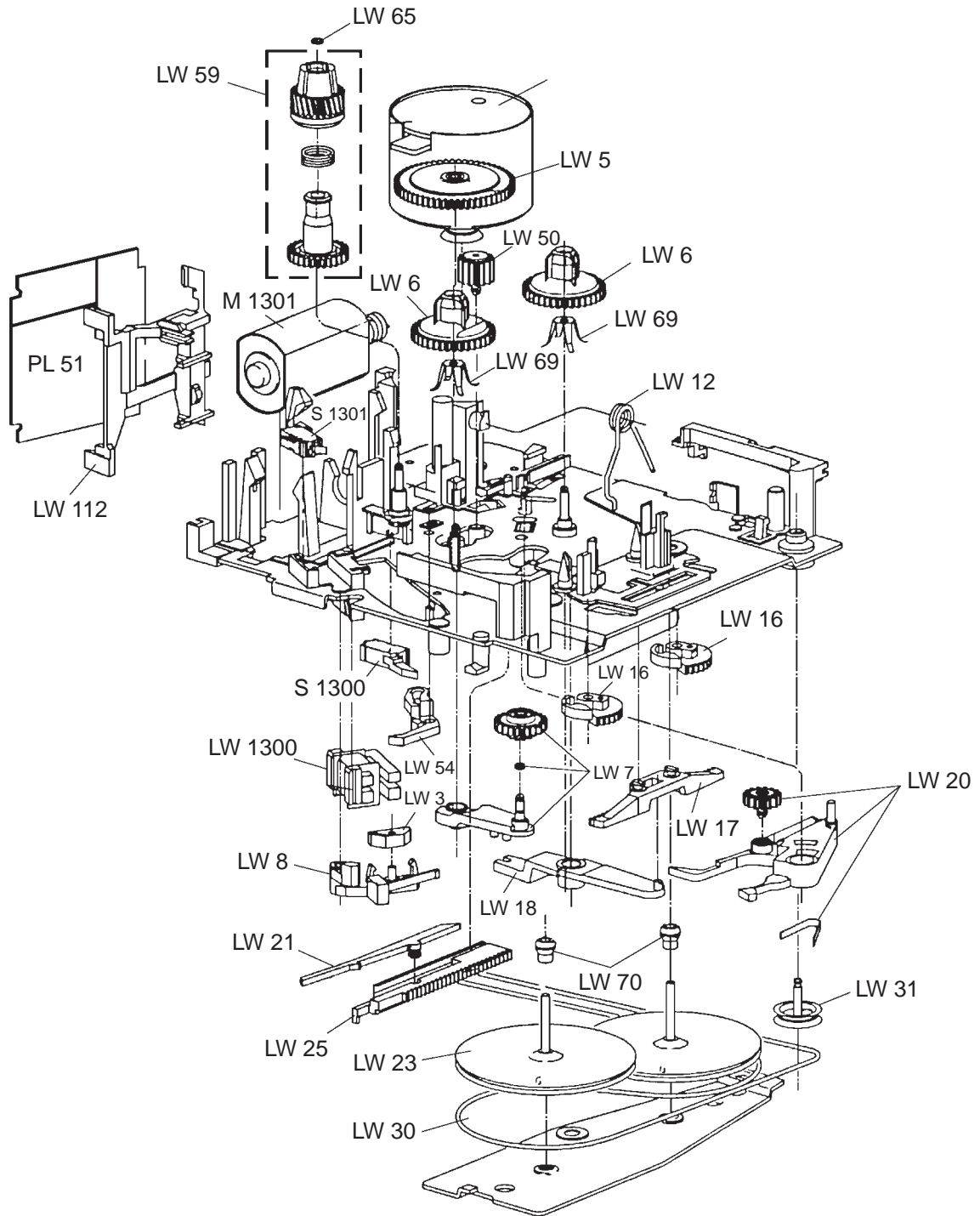

Position Position Position Posición	Bestell-Nr. Part no. No. de commande Número de pedido
LW 3	8 624 200 610
LW 5	8 626 300 452
LW 6	8 626 600 492
LW 7	8 626 300 453
LW 8	8 621 300 152
LW 12	8 624 600 887
LW 16	8 626 300 454
LW 17	8 621 901 746
LW 18	8 621 901 754
LW 20	8 621 901 747
LW 21	8 621 300 164
LW 23	8 626 600 491

Position Position Position Posición	Bestell-Nr. Part no. No. de commande Número de pedido
LW 25	8 621 901 750
LW 30	8 624 700 421
LW 32	8 626 600 490
LW 50	8 626 300 451
LW 54	8 621 901 751
LW 59	8 626 600 495
LW 65	8 620 105 450
LW 69	8 621 300 562
LW 70	8 620 300 126
LW 112	8 621 300 161
S 1300	8 622 002 113
S 1301	8 622 002 112

Position Position Position Posición	Bestell-Nr. Part no. No. de commande Número de pedido
LW 111 Kabelhalter/ Cable holder/ Porte-cable/ Sujecion de cable	8 620 600 027
LW 1300	8 624 200 608
M 1300 Motor	8 627 205 773
M 1301 Motor	8 627 205 774
PL 51	8 628 309 872

Explosionszeichnung / Exploded View / Vue éclatée / Dibujo de tipo explosión

8 638 811 912

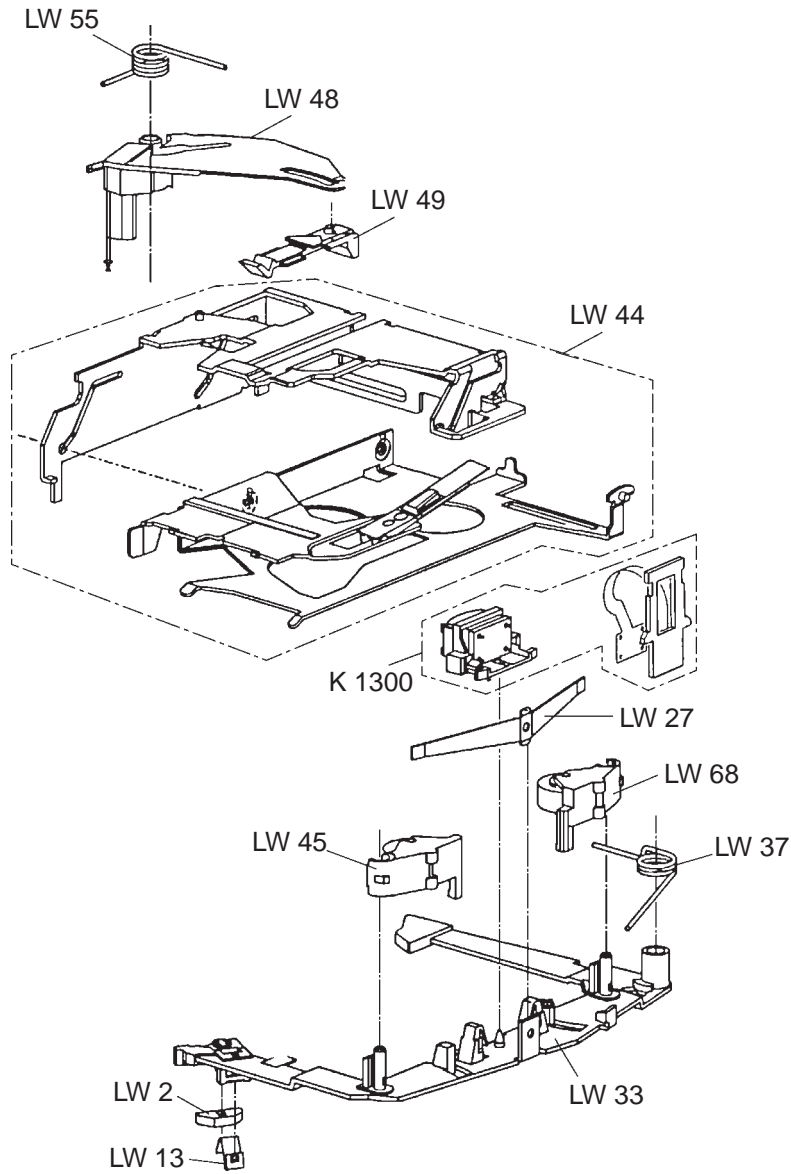

Position	Bestell-Nr.
Position	Part no.
Position	No. de commande
Posición	Número de pedido
LW 2	8 624 200 609
LW 13	8 621 300 163
LW 27	8 621 200 134
LW 33	8 621 300 564
K 1300	8 628 800 435
LW 37	8 624 600 885
LW 44	8 621 300 563
LW 45	8 626 600 493
LW 48	8 621 404 748
LW 49	8 621 901 749
LW 55	8 624 600 886
LW 68	8 626 600 494

Blaupunkt-Werke GmbH, Hildesheim

Änderungen vorbehalten! Nachdruck - auch auszugsweise - nur mit Quellenangabe gestattet

Gedruckt in Deutschland
Printed in Germany by HDR

Modification reserved! Reproduction - also by extract - only permitted with indication of sources used

Modification réservées! Reproduction - aussi en abrégé - permise seulement avec indication des sources utilisées

¡Modificaciones reservadas! Reproducción - también en parte - solamente permitida con indicación de las fuentes utilizadas

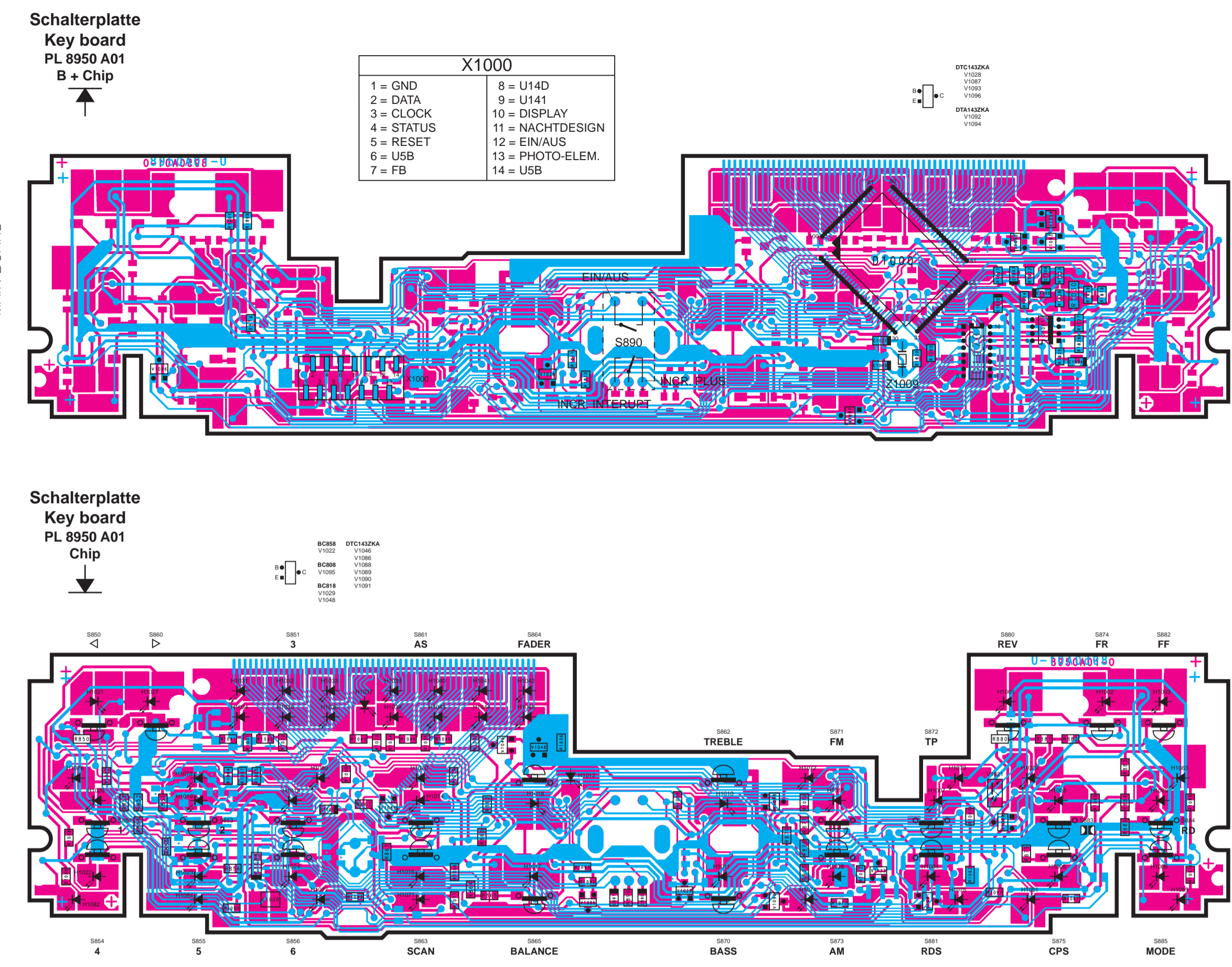
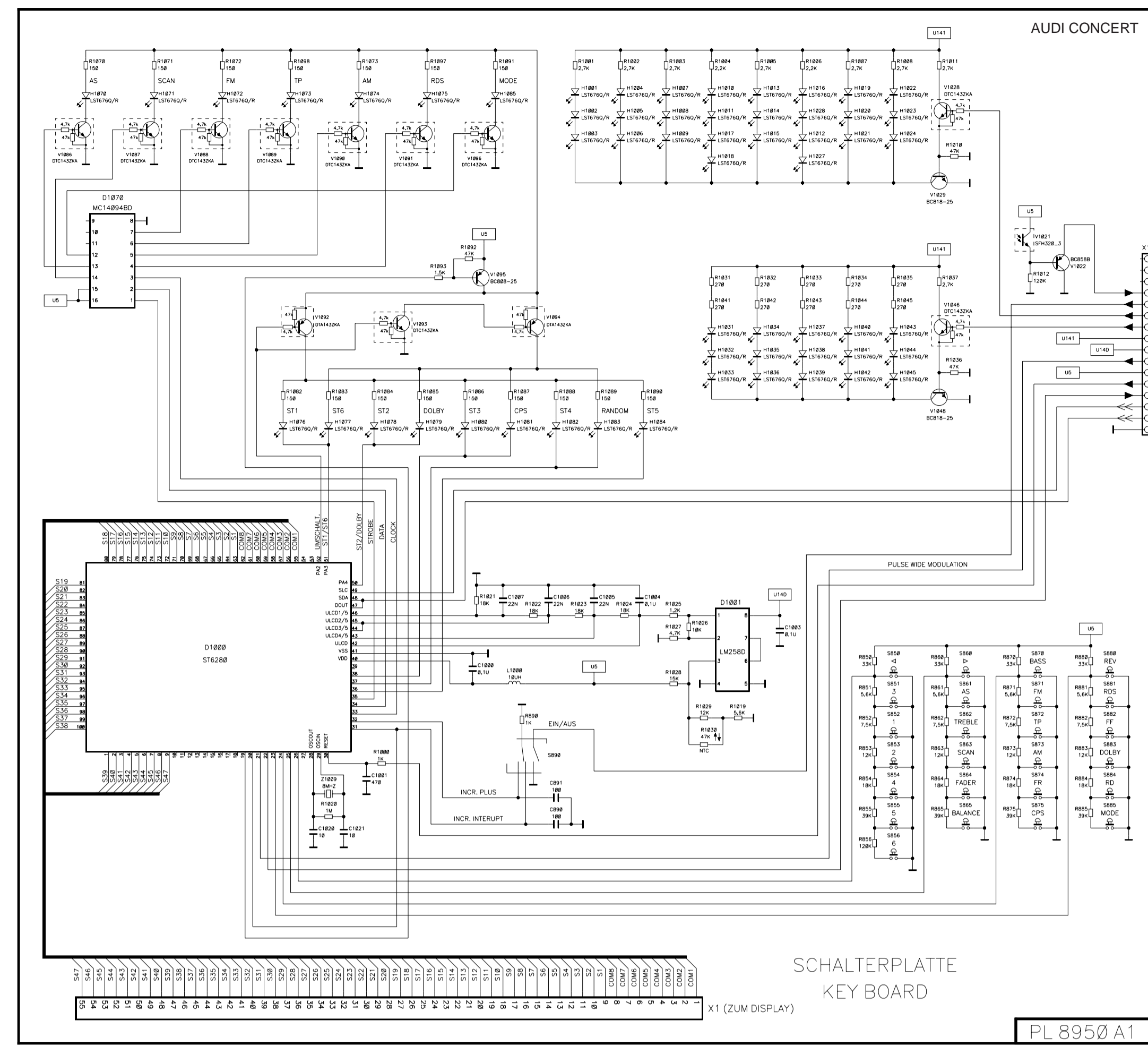
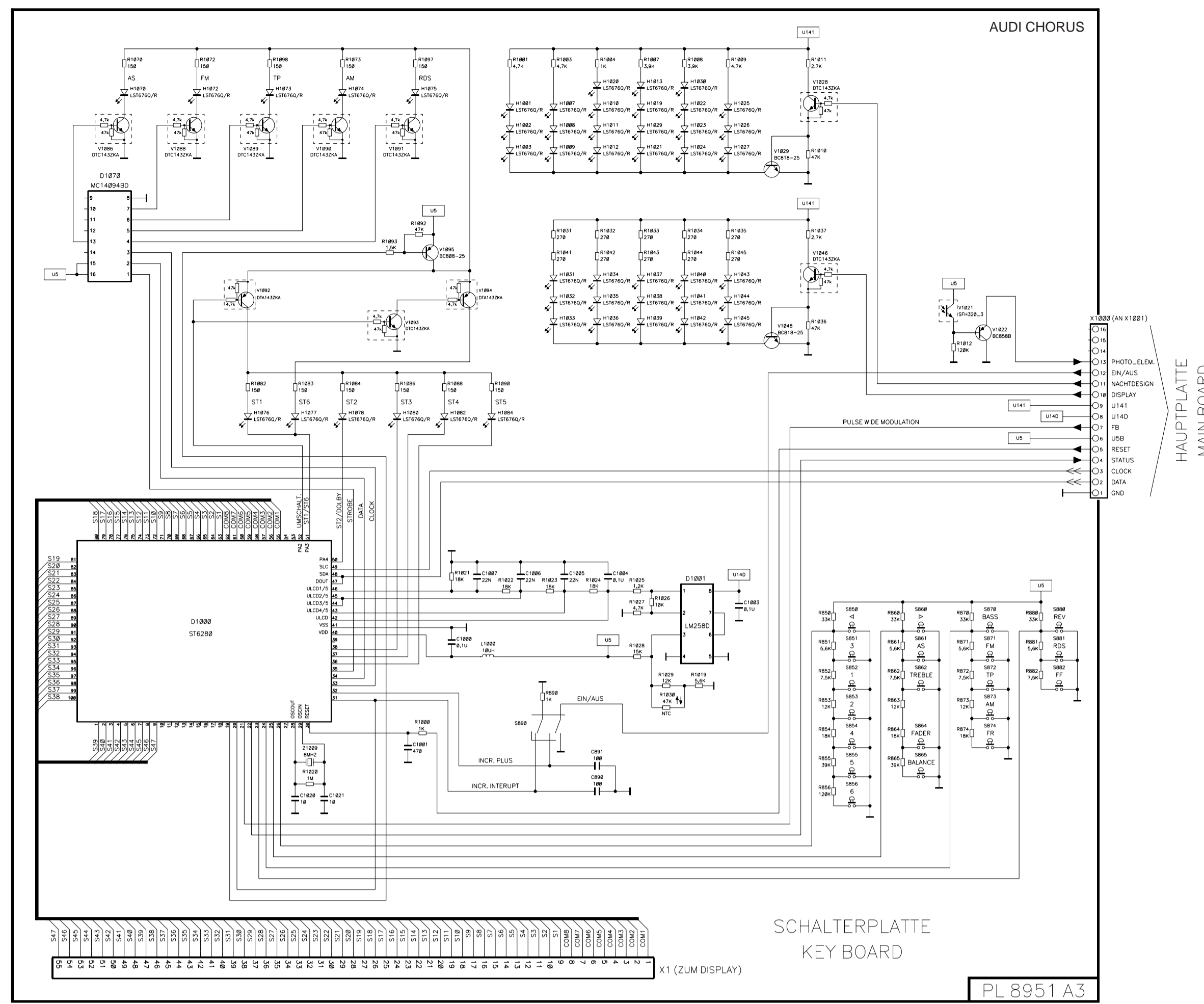

X1000

1 = GND	8 = U14D
2 = DATA	9 = U141
3 = CLOCK	10 = DISPLAY
4 = STATUS	11 = NIGHTDESIGN
5 = RESET	12 = EIN/AUS
6 = USB	13 = PHOTO-ELEM.
7 = FB	14 = USB

BC588

BC588	BC588A
V1002	V1002
V1003	V1003
V1004	V1004
V1005	V1005
V1006	V1006

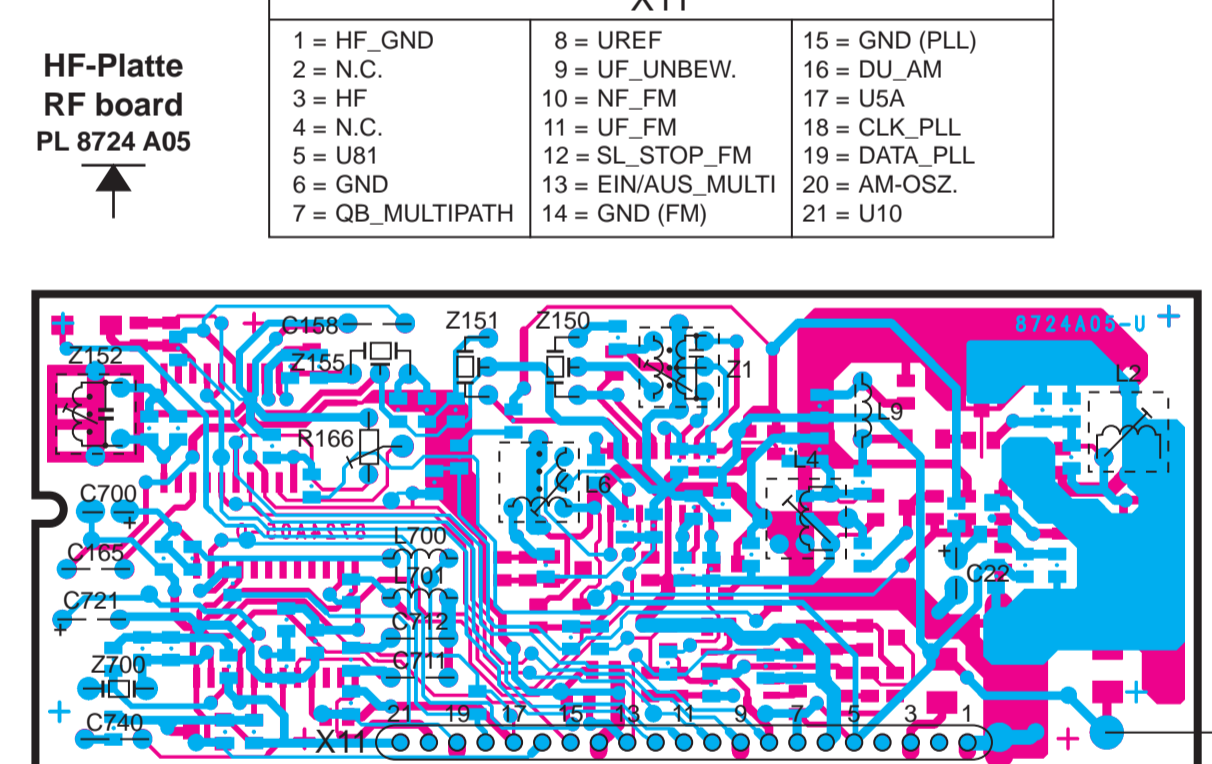
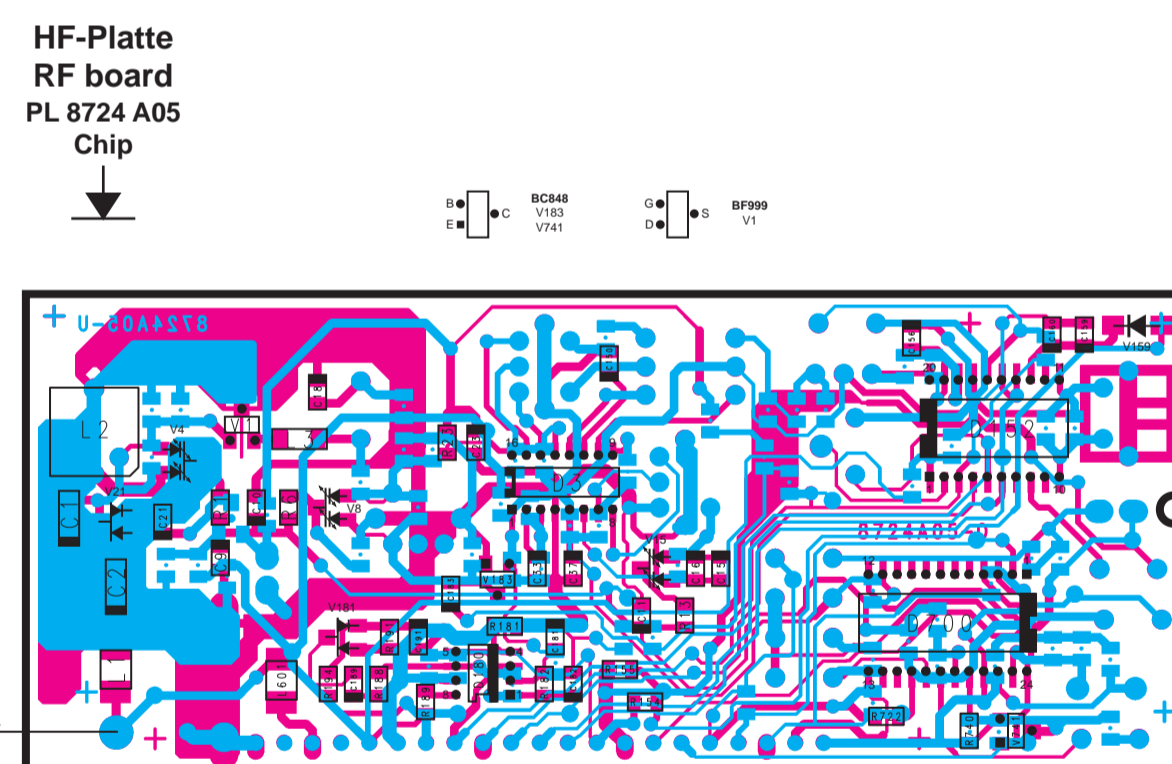
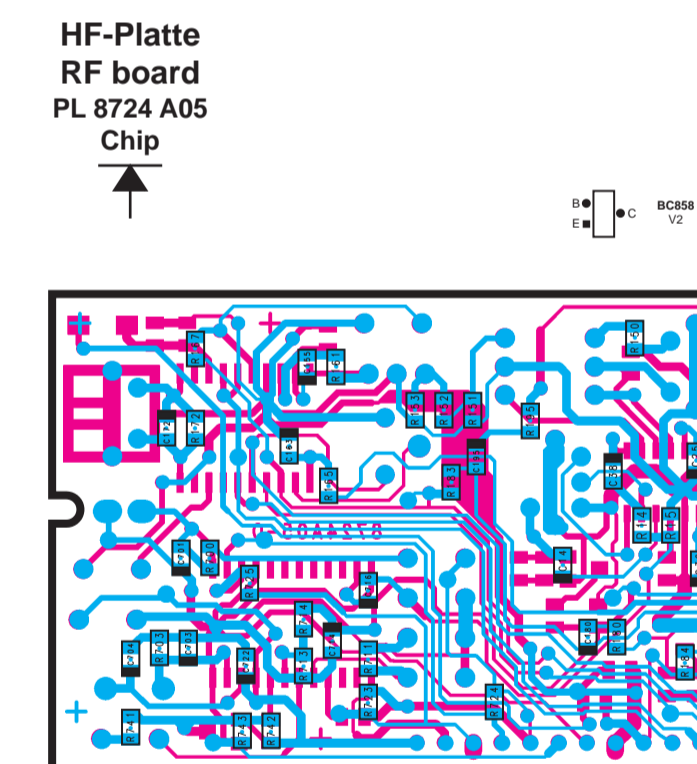

X11

1 = HF_GND	8 = UREF	15 = GND (PLL)
2 = N.C.	9 = UF_UNBEW.	16 = DU_AM
3 = HF	10 = NF_FM	17 = USA
4 = N.C.	11 = UF_FM	18 = CLK_PLL
5 = U81	12 = SL_STOP_FM	19 = DATA_PLL
6 = GND	13 = EIN/AUS_MULTI	20 = AM-OSZ.
7 = QB_MULTIPATH	14 = GND (FM)	21 = U10

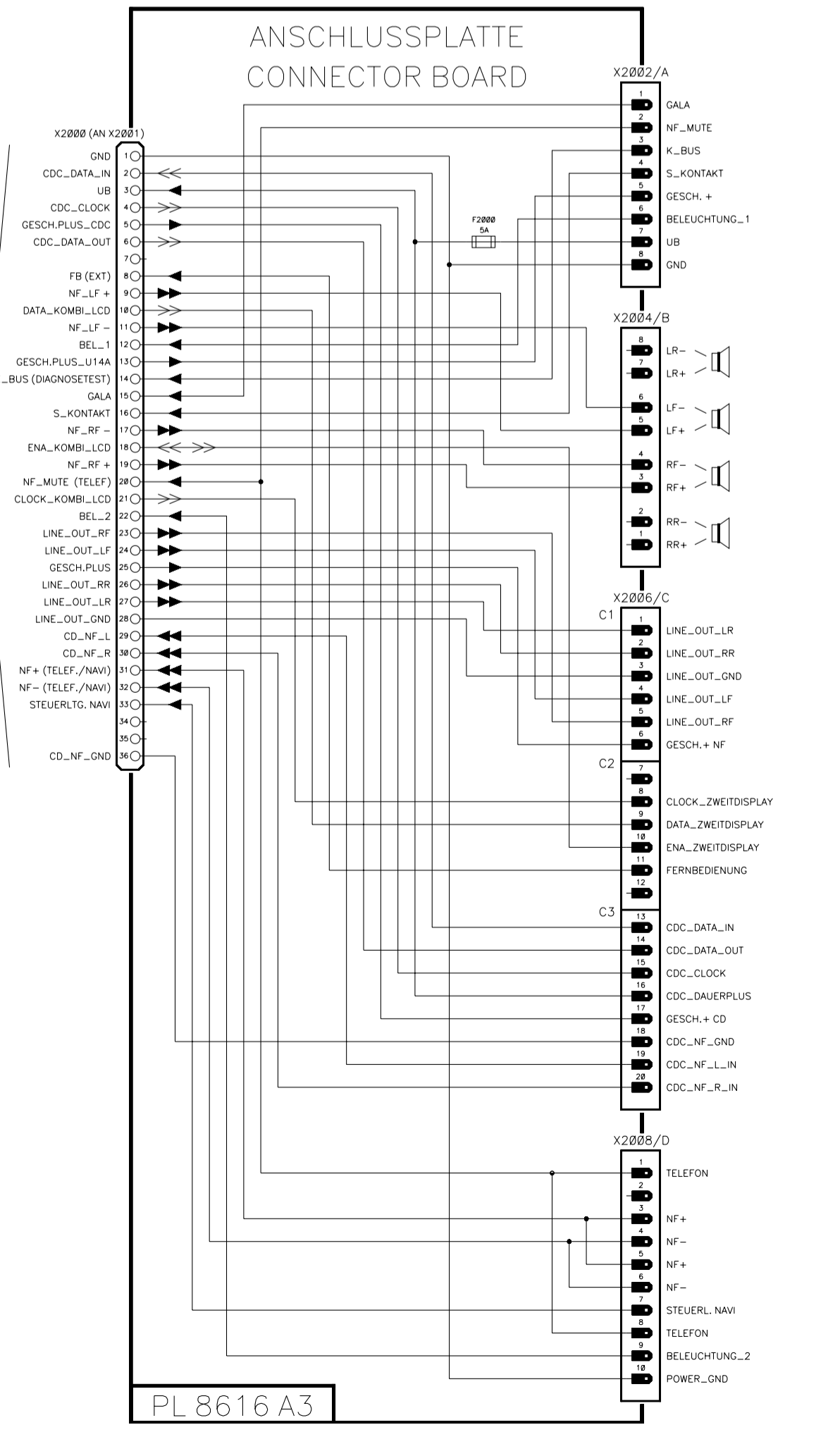
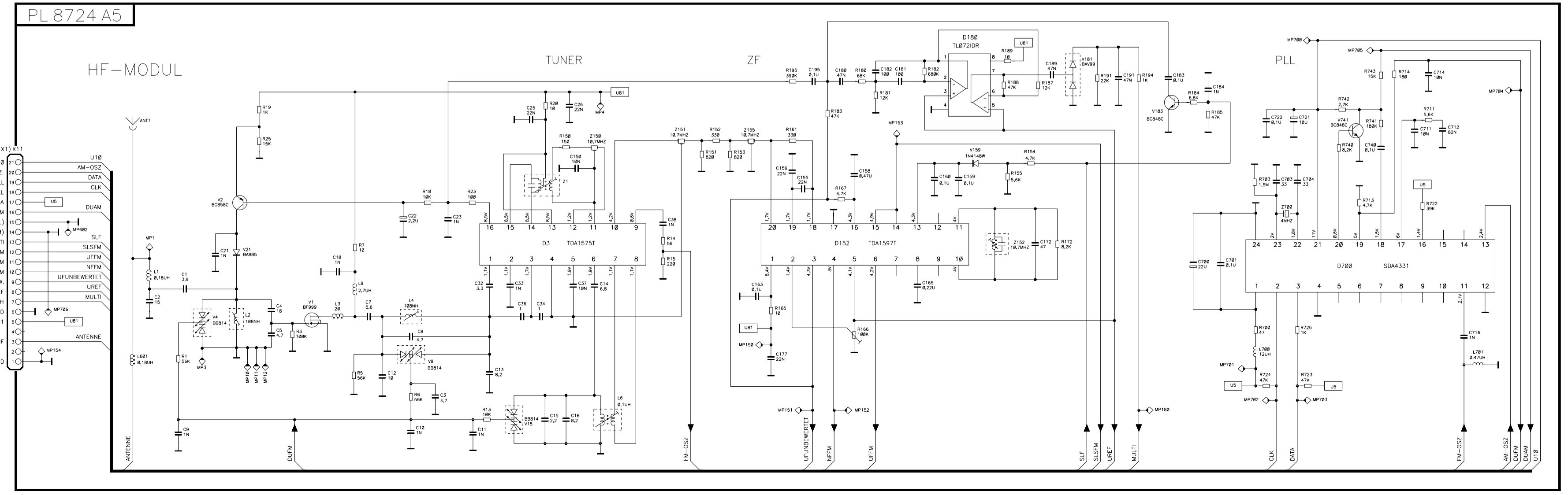

BLAUPUNKT AUTORADIO

Audi Chorus
7 646 243 380

Audi Chorus A8
7 647 243 380

Audi Concert
7 646 248 380

Audi Concert A8
7 647 248 380

Audi Concert Navi
7 647 249 380

8 622 401 339 BN-WG 08/97

Schaltbild • Circuit diagram • Schema du poste • Esquema del aparato

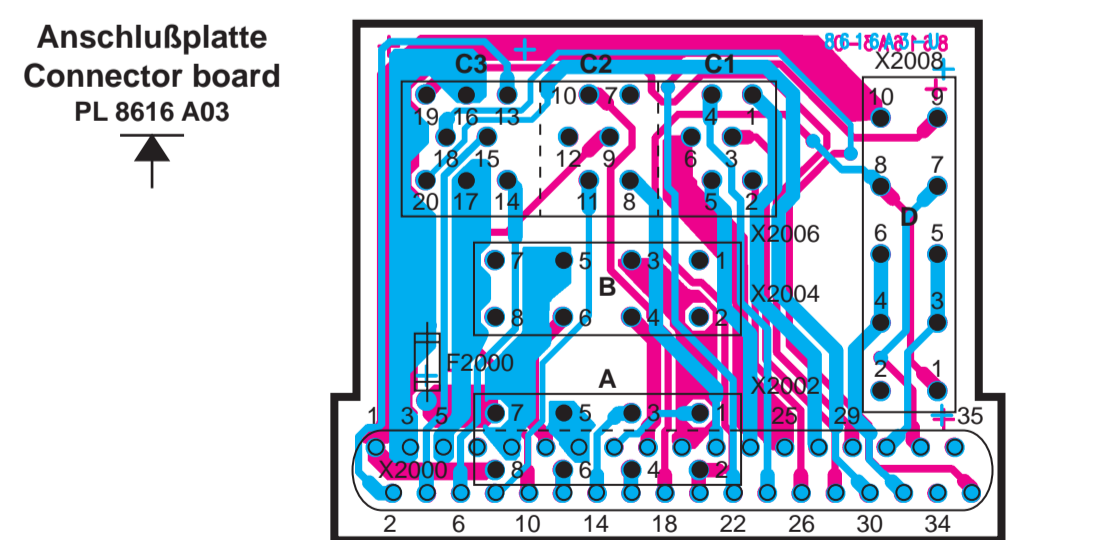

X2000

1 = GND	13 = GESCH.+ U14A	25 = GESCH.+
2 = CDC_DATA_IN	14 = K_BUS (DIAGN.)	26 = LINE_OUT_RR
3 = UB	15 = GALA	27 = LINE_OUT_LR
4 = CDC_CLOCK	16 = S_KONTAKT	28 = LINE_OUT_GND
5 = GESCH.+ CDC	17 = NF_RF	29 = CD_NF_L
6 = CDC_DATA_OUT	18 = ENA_KOMBI_LCD	30 = CD_NF_R
7 = N.C.	19 = NF_RF+	31 = NF+(TEL.NAVI)
8 = FB (EXT)	20 = NF_MUTE (TEL)	32 = NF-(TEL.NAVI)
9 = NF_LF+	21 = CLK_KOMBI_LCD	33 = STEUERL. NAVI
10 = DA_KOMBI_LCD	22 = BEL_2	34 =
11 = NF_LF-	23 = LINE_OUT_RF	35 =
12 = BEL_1	24 = LINE_OUT_LF	36 = CD_NF_GND

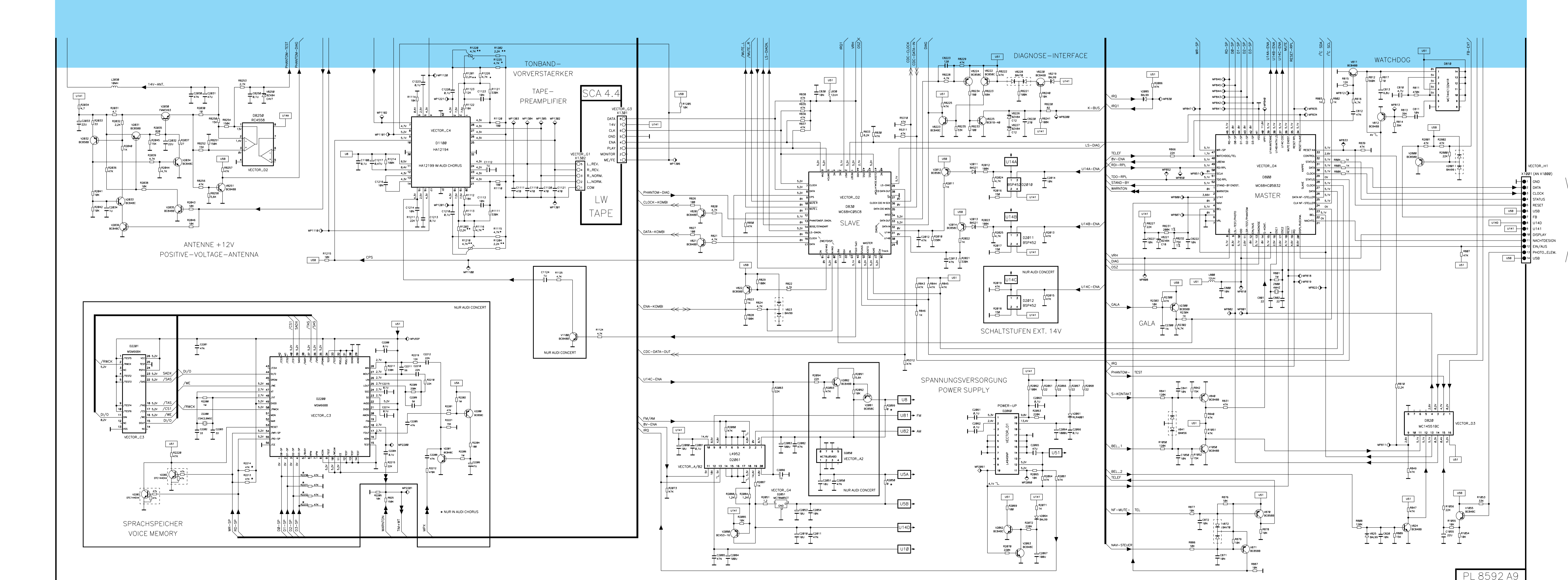
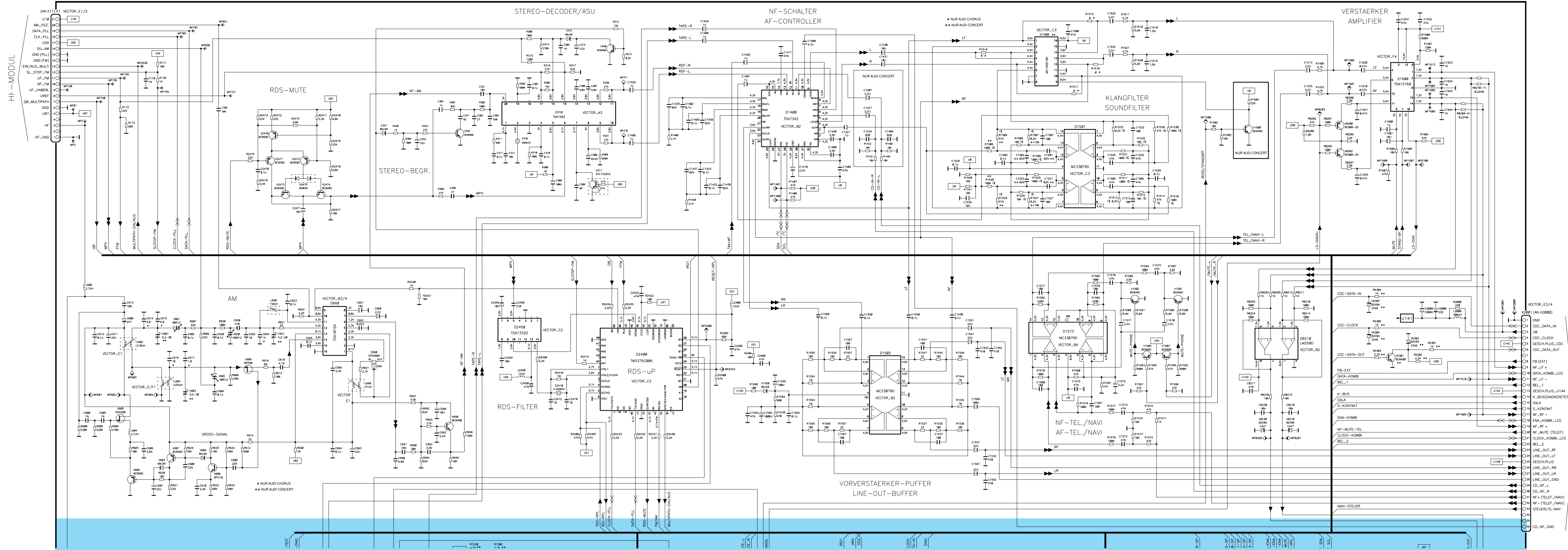

ANSCHLUSSPLATE

SCHALTERPLATE